

Harman Kardon AVR75 Audio/Video Receiver

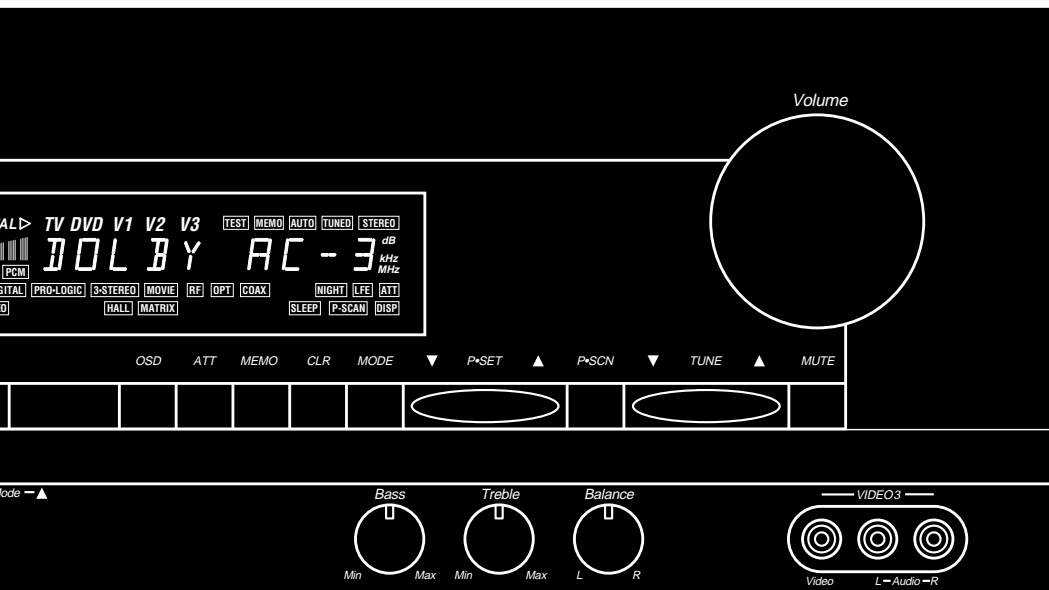

Owner's Manual

harman/kardon

Owner's Manual

AVR75 Audio/Video Receiver

Table of Contents

Introduction	1
Safety Information	2–3
Unpacking and Installation	3
Front Panel Controls	4–5
Front Panel Information Display	6–7
Rear Panel Connections	8–9
Remote Control Functions	10–12
Installation and Setup	13–14
Remote Control Programming and Operation	15–16
System Configuration	17–20
Basic Operation	21–24
Source Selection	21
Surround Mode Selection	21
Digital Audio Sources	22
Tuner Operation	22–24
On-Screen Display	25–27
Advanced Features	28–31
Audio Tape Dubbing	28
Delay Time Adjust	28–29
Digital Audio Playback	29–30
Surround Mode Chart	31
Troubleshooting Guide	32
Technical Specifications	33

harman/kardon
80 Crossways Park West
Woodbury, NY 11797

H A Harman International Company
www.harmankardon.com
©1997 Harman Kardon, Incorporated

Introduction

1

Congratulations! With the purchase of a Harman Kardon AVR75 you are about to begin many years of listening enjoyment. The AVR75 has been custom designed to provide all the excitement and detail of movie soundtracks and every subtle nuance of musical selections. With on board Dolby* Digital Decoding, the AVR75 delivers six discrete channels of audio that take advantage of the digital soundtracks from the latest DVD and LV releases.

While complex digital systems are hard at work within the AVR75 to make all of this happen, hook-up and operation are simple. Color-keyed connections, a comprehensive remote control and on-screen menus make the AVR75 easy to use. To obtain the maximum enjoyment from your new receiver we urge you to take a few minutes to read through this manual. This will ensure that connections to speakers, source playback units and other external devices are made properly. In addition, a few minutes spent learning the functions of the various controls will enable you to take advantage of all the power the AVR75 is able to deliver.

If you have any questions about this product, its installation or operation, please contact your retailer or custom installer. They are your best local source of information.

Description and Features

The AVR75 is a full-featured A/V receiver, incorporating a wide variety of listening options. In addition to Dolby Digital decoding, Dolby Pro Logic* and Dolby 3 Stereo are available for compatibility with the tens of thousands of movies and television programs encoded with analog surround information. A choice of Hall, Matrix and Movie modes is also available for use with both encoded sources and traditional two-channel stereo recordings.

A total of five audio/video inputs, each with both composite and S-Video, as well as three additional audio only inputs are selected through a learning remote control and an easy to read front panel display or on-screen graphics through a TV monitor.

The AVR75's powerful amplifier uses traditional Harman Kardon High Current design philosophies to meet the wide dynamic range of any program selection.

Harman Kardon invented the high-fidelity receiver over forty years ago. With state-of-the-art circuitry and time-honored circuit designs, the AVR75 is undoubtedly the finest receiver ever offered by Harman Kardon.

- On-Board Dolby Digital Decoding
- Coax, Optical or RF Digital Inputs
- On-Screen Menu Displays
- Learning Remote Control
- Composite and S-Video Switching
- Preamp Output for ALL Channels Permits Ease of Expansion

Safety Information

Important Safety Information

Verify Line Voltage Before Use

Your AVR75 has been designed for use with 120-volt AC current. Connection to a line voltage other than that for which it is intended can create a safety and fire hazard, and may damage the unit.

If you have any questions about the voltage requirements for your specific model, or about the line voltage in your area, contact your selling dealer before plugging the unit into a wall outlet.

Do Not Use Extension Cords

To avoid safety hazards, use only the power cord attached to your unit. We do not recommend that extension cords be used with this product. As with all electrical devices, do not run power cords under rugs or carpets or place heavy objects on them. Damaged power cords should be replaced immediately with cords meeting factory specifications.

Handle the AC Power Cord Gently

When disconnecting the power cord from an AC outlet, always pull the plug, never pull the cord. If you do not intend to use the unit for any considerable length of time, disconnect the plug from the AC outlet.

Do Not Open The Cabinet

There are no user-serviceable components inside this product. Opening the cabinet may present a shock hazard, and any modification to the product will void your guarantee. If water or any metal object such as a paper clip, wire or a staple accidentally falls inside the unit, disconnect it from the AC power source immediately, and consult an authorized service station.

CATV or Antenna Grounding





If an outside antenna or cable system is connected to this product, be certain that it is grounded so as to provide some protection against voltage surges and static charges. Section 810 of the National Electrical Code, ANSI/NFPA No. 70-1984, provides information with respect to proper grounding of the mast and supporting structure, grounding of the lead-in wire to an antenna discharge unit, size of grounding conductors, location of antenna discharge unit, connection to grounding electrodes and requirements of the grounding electrode.

NOTE TO CATV SYSTEM INSTALLER:

This reminder is provided to call the CATV (Cable TV) system installer's attention to article 820-40 of the NEC that provides guidelines for proper grounding and, in particular, specifies that the cable ground shall be connected to the grounding system of the building, as close to the point of cable entry as possible.

Installation Location

- To assure proper operation, and to avoid the potential for safety hazards, place the unit on a firm and level surface. When placing the unit on a shelf, be certain that the shelf and any mounting hardware can support the weight of the product.
- Make certain that proper space is provided both above and below the unit for ventilation. If this product will be installed in a cabinet or other enclosed area, make certain that there is sufficient air movement within the cabinet. Under some circumstances a fan may be required.
- Do not place the unit directly on a carpeted surface.
- Avoid installation in extremely hot or cold locations, or an area that is exposed to direct sunlight or heating equipment.
- Avoid moist or humid locations.
- Do not obstruct the ventilation slots on the top of the unit, or place objects directly over them.

	CAUTION RISK OF ELECTRIC SHOCK DO NOT OPEN	
CAUTION: TO REDUCE THE RISK OF ELECTRIC SHOCK, DO NOT REMOVE COVER (OR BACK). NO USER-SERVICEABLE PARTS INSIDE. REFER SERVICING TO QUALIFIED SERVICE PERSONNEL.		
 <p>The lightning flash with arrowhead symbol, within an equilateral triangle, is intended to alert the user to the presence of uninsulated "dangerous voltage" within the product's enclosure that may be of sufficient magnitude to constitute a risk of electric shock to persons.</p>	 <p>The exclamation point within an equilateral triangle is intended to alert the user to the presence of important operating and maintenance (servicing) instructions in the literature accompanying the appliance.</p>	
WARNING: TO REDUCE THE RISK OF FIRE OR ELECTRIC SHOCK, DO NOT EXPOSE THIS APPLIANCE TO RAIN OR MOISTURE.		
CAUTION: TO PREVENT ELECTRIC SHOCK, MATCH WIDE BLADE OF PLUG TO WIDE SLOT, FULLY INSERT. ATTENTION: POUR EVITER LES CHOCS ELECTRIQUES, INTRODUIRE LA LAME LA PLUS LARGE DE LA FICHE DANS LA BORNE CORRESPONDANTE DE LA PRISE ET POUSSER JUSQU'AU FOND.		

Safety Information

Cleaning

When the unit gets dirty, wipe it with a clean, soft dry cloth. If necessary, wipe it with a soft cloth dampened with mild soapy water, then a fresh cloth with clean water. Wipe dry immediately with a dry cloth. NEVER use benzene, aerosol cleaners, thinner, alcohol or any other volatile cleaning agent. Do not use abrasive cleaners, as they may damage the finish of metal parts. Avoid spraying insecticide near the unit.

Moving The Unit

Before moving the unit, be certain to disconnect any interconnection cords with other components, and make certain that you disconnect the unit from the AC outlet.

Important information for the user

NOTE: This equipment has been tested and found to comply with the limits for a Class B digital device, pursuant to Part 15 of the FCC Rules. The limits are designed to provide reasonable protection against harmful interference in a residential installation. This equipment generates, uses and can radiate radio frequency energy and, if not installed and used in accordance with the instructions, may cause harmful interference to radio communication. However, there is no guarantee that harmful interference will not occur in a particular installation. If this equipment does cause harmful interference to radio or television reception, which can be determined by turning the equipment off and on, the user is encouraged to try to correct the interference by one or more of the following measures:

- Reorient or relocate the receiving antenna.
- Increase the separation between the equipment and receiver.
- Connect the equipment into an outlet on a circuit different from that to which the receiver is connected.
- Consult the dealer or an experienced radio/TV technician for help.

This device complies with Part 15 of the FCC Rules. Operation is subject to the following two conditions: (1) this device may not cause harmful interference, and (2) this device must accept interference received, including interference that may cause undesired operation.

NOTE: Changes or modifications may cause this unit to fail to comply with Part 15 of the FCC Rules and may void the user's authority to operate the equipment.

Unpacking and Installation

The carton and shipping materials used to protect your new receiver during shipment were specially designed to cushion it from shock and vibration. We suggest that you save the carton and packing materials for use in shipping if you move or should the unit ever need repair.

To minimize the size of the carton in storage, you may wish to flatten it. This is done by carefully slitting the tape seams on the bottom and collapsing the carton down to a more two-dimensional appearance. Other cardboard inserts may be stored in the same manner. Packing materials that cannot be collapsed should be saved along with the carton in a plastic bag.

If you do not wish to save the packaging materials, please note that the carton and other sections of the shipping protection are recyclable. Please respect the environment and discard those materials at a local recycling center.

Typographic Conventions

In order to help you use this manual with the remote control, front panel controls, rear panel connections and on-screen menus, certain conventions have been used.

EXAMPLE – (bold type) indicates a specific remote control or front panel button, or rear panel connection jack

EXAMPLE – (OCR type) indicates a message that is visible through the on-screen menu system

1 – (number in a square) indicates a specific front panel control

1 – (number in an oval) indicates a button or indicator on the remote

1 – (number in a circle) indicates a rear panel connection

A – (letter in a square) indicates an indicator in the front panel display

Front Panel Controls

4

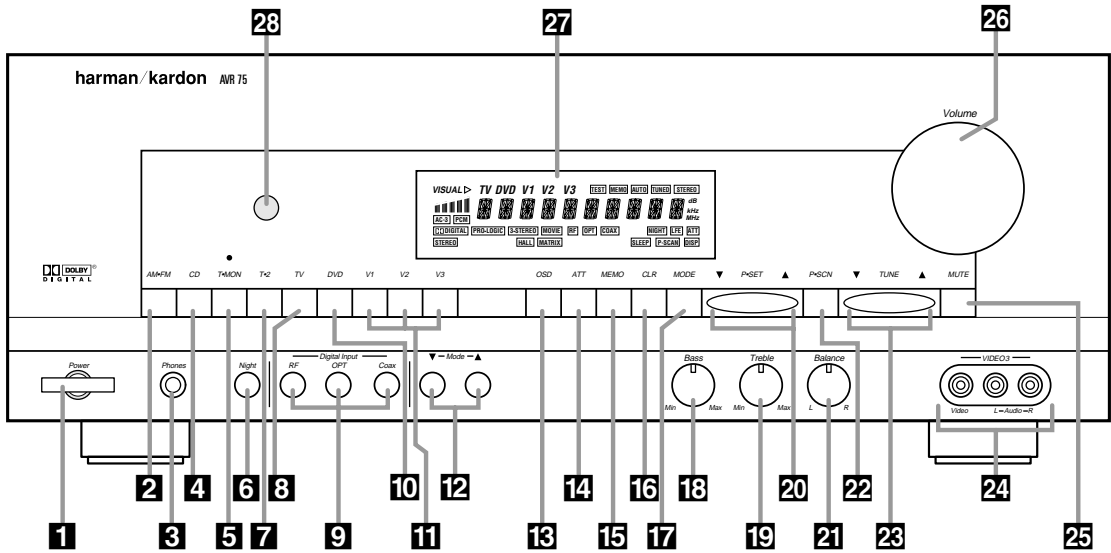

- | | | |
|------------------------------------|---|--------------------------------|
| 1 Power | 11 Video Sources | 21 Balance |
| 2 AM/FM Tuner Mode Selector | 12 Mode | 22 P-Scan |
| 3 Headphone Jack | 13 OSD (On-Screen Display) | 23 Tune |
| 4 CD | 14 ATT (Attenuation) Mode Select | 24 Video 3 Input |
| 5 Tape 1/Monitor | 15 Memo | 25 Mute |
| 6 Night Mode | 16 Clear | 26 Volume Control |
| 7 Tape 2 | 17 FM Mode | 27 Information Display |
| 8 TV Input | 18 Bass | 28 Remote Sensor Window |
| 9 Digital Input Selectors | 19 Treble | |
| 10 DVD Input | 20 P-Set | |

Front Panel Controls

5

1 Power: Press this button once to turn the unit on and off. Once the unit is turned on, it may be turned off and then on again from the remote, if desired.

NOTE: When the remote is used to turn the unit off the LED surrounding the Power Switch will turn amber, indicating that the AVR75 is in a Standby mode. In this condition the unit is NOT disconnected from the AC main power supply.

2 AM/FM Tuner Selector: Press this button once to select the tuner. Press it again to switch between AM and FM.

3 Headphone Jack: Plug standard stereo headphones into this jack for private listening.

NOTE: When the headphones are in use the output to the speakers is muted and the surround mode is automatically switched to **STEREO**. When the headphones are removed from the jack, sound to the speakers is restored and the unit returns to the previous sound mode.

4 CD: Press this button to select the CD player.

5 Tape1/Monitor: Press this button to select Tape One as the input source. A red LED above the button will illuminate to indicate that the Tape Monitor has been selected.

6 Night Mode: Press this button to activate the "Night" mode, preventing loud playback when the digital modes are in use.

7 Tape 2: Press this button to select Tape 2 input.

8 TV Input: Press this button to select the source connected to the TV Input **9**.

9 Digital Input Selectors: Press one of these buttons to select a digital input source. The digital audio source may be the same as, or different from, the analog audio of the selected video source.

10 DVD Input: Press this button to select the source connected to the DVD Input **8**. Note that if the DVD or LV player's digital audio output is used, it must be selected separately using the **Digital Input Selectors 9-7**.

11 Video Sources: Press any of these buttons to select a video input source.

12 Mode: Press these buttons to scroll up **▲** or down **▼** through the list of available surround modes.

13 OSD (On-Screen Display): Press the button briefly to display a system status report on your video screen.

14 ATT (Attenuation) Mode Select: Press this button to activate the Attenuation mode which cuts the analog input signal by 50% to compensate for high-level input sources.

15 Memo: The memo button is used to enter stations to the tuner's preset memory in either the manual or automatic modes.

16 Clear: The clear button is used to cancel tuning, memory input or when clearing the unit's memories.

17 FM Mode: Press this button to select the tuning mode for FM stations.

18 Bass: This knob adjusts the tone of low-frequency sounds. Turn it to the right to boost bass frequencies or to the left to cut bass frequencies.

19 Treble: This knob adjusts the tone of high-frequency sounds. Turn it to the right to boost high frequencies or to the left to cut high frequencies.

20 P-Set: Press this button to manually scroll up **▲** or down **▼** through the FM or AM stations programmed into the receiver's preset memory.

21 Balance: This knob adjusts the balance between the front left and right speakers.

22 P-Scan: Press this button to automatically scan through the FM or AM stations preset into the receiver's memory. Press the button again to stop the scan when the tuner is at the desired station.

23 Tune: Press this button to manually scan up **▲** or down **▼** through the FM or AM bands.

24 Video 3 Input: Audio or Video sources connected to these jacks may be selected by pressing the **Video Source** button **11**.

25 Mute: Press this button to cut the output to the speakers. Press it again to return to the previous volume level.

26 Volume Control: Turn the knob clockwise to increase volume, counterclockwise to decrease the volume. Note that approximately two revolutions of the knob are required to go from no output to maximum volume.

27 Information display: This display delivers messages and status indications to help you operate the receiver. Refer to the separate diagram for complete explanation of the FL display.

28 Remote Sensor Window: The sensor behind this window receives infrared signals from the remote control. Aim the remote at this area and do not block or cover it unless an external remote sensor is installed.

Front Panel Information Display

6

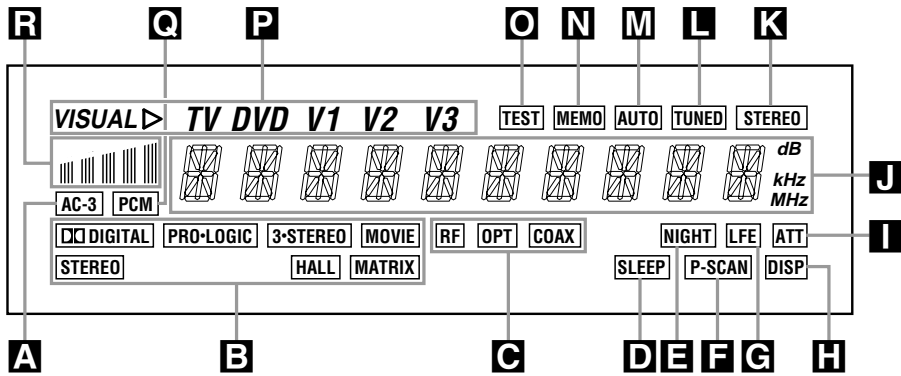

- A** AC-3 Indicator
- B** Surround Mode Status
- C** Digital Mode Indicators
- D** Sleep Indicator
- E** Night Indicator
- F** P-Scan

- G** LFE Indicator
- H** DISP
- I** ATT Indicator
- J** Main Information Display
- K** Stereo
- L** Tuned

- M** Auto
- N** Memo
- O** Test
- P** "Visual" Indicator
- Q** PCM Indicator
- R** Signal Level Indication

Front Panel Information Display

7

A AC-3 Indicator: This indicator illuminates when the AVR75 is decoding a Dolby Digital input source.

B Surround Mode Status: These indicators display the currently selected surround mode.

C Digital Mode Indicators: These indicators show which digital input is in use.

D Sleep Indicator: This indicator lights when the AVR75 is in the Sleep mode.

E Night Indicator: This indicator lights when the AVR75 is in the Night mode, which prevents the AVR75 from loud playback when digital sources are in use.

F P-Scan: This indicator flashes when the stations programmed into the tuner memory are being automatically reviewed.

G LFE Indicator: This indicator will illuminate when the Low-Frequency Effects (LFE) option has been turned on through the controls in **SETUP MENU 3**.

H DISP: This indicator lights when the FL display has been turned off using the **Display** button **16** to remind you that the unit is still turned on.

I ATT Indicator: This indicator lights when the Attenuation function has been engaged to cut the input from analog sources by approximately 50%.

J Main Information Display: This ten-digit display shows messages relating to the status, input source, surround mode, tuner, volume level or other aspects of unit's operation.

K Stereo: This indicator lights when an FM station is broadcasting in stereo.

L Tuned: This indicator lights when an AM or FM station is properly tuned and locked.

M Auto: This indicator signifies that the Automatic Tuning mode is in use for FM broadcasts.

N Memo: This indicator flashes when the **Memo** button is pressed when entering presets and other information into the tuner's memory.

O Test: This indicator flashes when the output levels are being set using the built-in test signal generator.

P "Visual" Indicator: These indicators display which input source is being fed to the video monitor output.

Q PCM Indicator: This indicator illuminates to show that a standard PCM (S/P-DIF) digital audio signal is being decoded by the digital-to-analog converter.

R Signal Level Indication: This is a visual indication of the strength of a radio station signal. The more bars visible, the stronger the station.

Rear Panel Connections

8

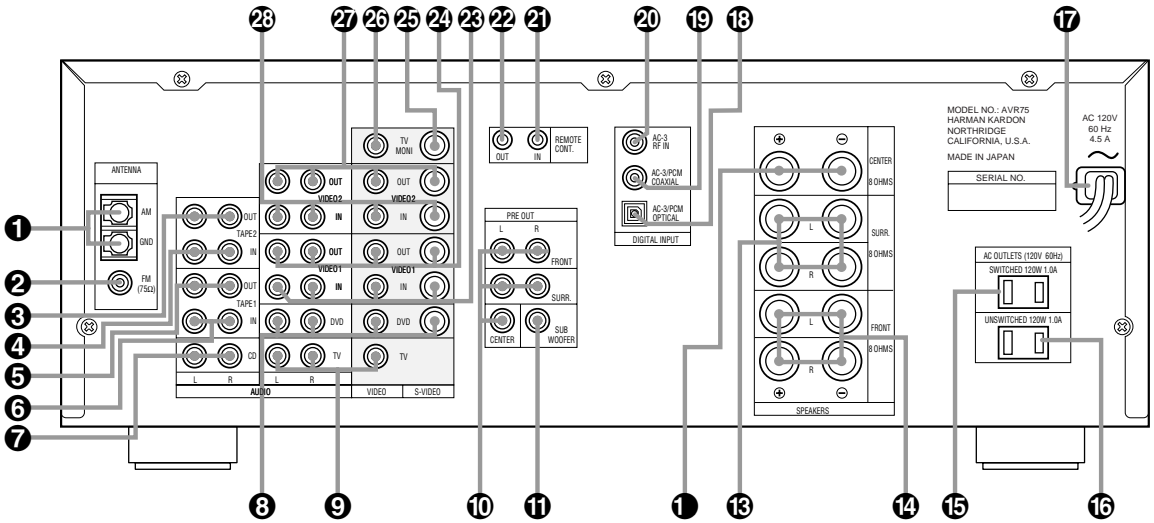

- 1 AM Antenna
- 2 FM Antenna
- 3 Tape 2 Out
- 4 Tape 2 In
- 5 Tape 1 Out
- 6 Tape 1 In
- 7 CD IN
- 8 DVD Inputs
- 9 TV Inputs
- 10 Pre-Outs

- 11 Subwoofer Pre-Out
- 12 Center
- 13 Surround
- 14 Front
- 15 Switched AC Outlet
- 16 Unswitched AC Outlet
- 17 Power Cable
- 18 AC-3/PCM Optical Input
- 19 AC-3/PCM Coaxial Input
- 20 AC-3 RF Input

- 21 Remote IR In
- 22 Remote IR Out
- 23 VCR 1 Inputs
- 24 VCR 1 Outputs
- 25 TV Monitor S-Video Output
- 26 TV Monitor Video Output
- 27 VCR 2 Outputs
- 28 VCR 2 Inputs

Rear Panel Connections

9

1 AM Antenna: Connect the AM loop antenna supplied with the receiver to these terminals. If an external AM antenna is used, make connections to the **AM** and **GND** terminals in accordance with the instructions supplied with the antenna.

2 FM Antenna: Connect an indoor or external FM antenna to this terminal.

3 Tape 2 Out: Connect these jacks to the RECORD/INPUT jacks of a second audio recorder.

4 Tape 2 In: Connect these jacks to the PLAY/OUT jacks of a second audio recorder.

5 Tape 1 Out: Connect these jacks to the RECORD/INPUT jacks of an audio recorder.

6 Tape 1 In: Connect these jacks to the PLAY/OUT jacks of an audio recorder.

7 CD IN: Connect these jacks to the output of a compact disc player or CD changer.

8 DVD Inputs: Connect the analog audio outputs and composite or S-Video output of a DVD or LV player to these jacks.

9 TV Inputs: Connect these jacks to the audio and video outputs of a TV Tuner, Cable TV converter box, satellite receiver, or any other audio/video source.

10 Pre-Outs: If external power amplifiers are used for any channels, connect them to these jacks.

11 Subwoofer Pre-Out: Connect this jack to the line level input of a powered subwoofer. If an external subwoofer amplifier is used, connect this jack to the subwoofer amplifier input.

1 Center: Connect these terminals to the center speaker.

13 Surround: Connect these terminals to the surround speakers.

14 Front: Connect these terminals to the front speakers.

15 Switched AC Outlet: This outlet may be used to power any device that you wish to have on when the unit is turned on.

16 Unswitched AC Outlet: This outlet may be used to power any AC device. The power will remain on at this outlet regardless of whether the AVR75 is on or off.

NOTE: The power consumption of the device plugged into each of these outlets should not exceed 120 watts.

17 Power Cable: Connect the AC plug to a non-switched AC wall outlet.

18 AC-3/PCM Optical Input: Connect the optical digital output from a DVD player, HDTV receiver, LV player or CD player to this jack. The signal may be either a Dolby Digital (AC-3*) signal or a standard PCM digital source.

19 AC-3/PCM Coaxial Input: Connect the coax digital output from a DVD player, HDTV receiver, LV player or CD player to this jack. The signal may be either a Dolby Digital (AC-3) signal or a standard PCM digital source.

20 AC-3 RF Input: Connect the AC-3 RF output of an LV player equipped for digital audio to this jack.

NOTE: Do not connect standard analog audio sources to these jacks

18 19 20.

21 Remote IR In: If the AVR75's front panel IR sensor is blocked due to cabinet doors or other obstructions, an external IR sensor may be used. Connect the output of the sensor to this jack.

22 Remote IR Out: This connection permits the IR sensor in the receiver to serve other remote controlled devices. Connect this jack to the "IR IN" jack on Harman Kardon or other compatible equipment.

23 VCR 1 Inputs: Connect these jacks to the audio, video and S-Video PLAY/OUT jacks of a VCR.

24 VCR 1 Outputs: Connect these jacks to the audio, video and S-Video RECORD/IN jacks of a VCR.

25 TV Monitor S-Video Output: Connect this jack to the S-Video input of a TV monitor or video projector to view S-Video sources selected by the receiver's video switcher.

NOTE: Standard (composite) video and S-Video signals will appear only at their respective output. The AVR75 does not convert one video format to another.

25 TV Monitor Video Output: Connect this jack to the standard (composite) video input of a TV monitor or video projector to view the on-screen menus and the output of any standard video source selected by the receiver's video switcher.

27 VCR 2 Outputs: Connect these jacks to the audio, video and S-Video RECORD/IN jacks of a second VCR.

28 VCR 2 Inputs: Connect these jacks to the audio, video and S-Video PLAY/OUT jacks of a second VCR.

Remote Control Functions

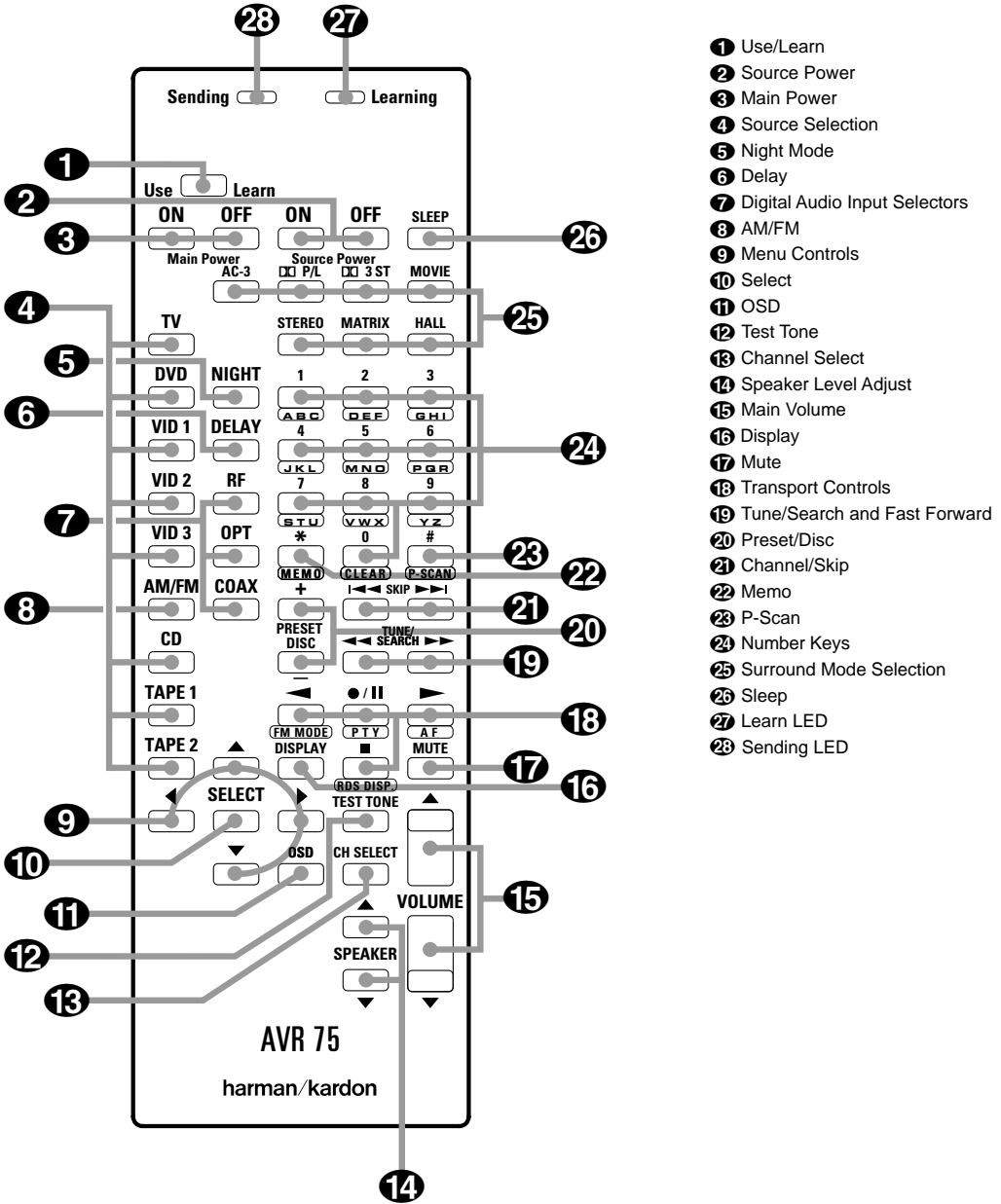

- 1 Use/Learn
- 2 Source Power
- 3 Main Power
- 4 Source Selection
- 5 Night Mode
- 6 Delay
- 7 Digital Audio Input Selectors
- 8 AM/FM
- 9 Menu Controls
- 10 Select
- 11 OSD
- 12 Test Tone
- 13 Channel Select
- 14 Speaker Level Adjust
- 15 Main Volume
- 16 Display
- 17 Mute
- 18 Transport Controls
- 19 Tune/Search and Fast Forward
- 20 Preset/Disc
- 21 Channel/Skip
- 22 Memo
- 23 P-Scan
- 24 Number Keys
- 25 Surround Mode Selection
- 26 Sleep
- 27 Learn LED
- 28 Sending LED

Remote Control Functions

11

1 Use/Learn: This switch selects the operation mode of the remote control. Slide it to the left for normal operation. Slide it to the right when the remote is being programmed.

2 Source Power: Press these buttons to control power for the last source device selected when power on/off commands have been programmed into the remote's memory.

3 Main Power: Press these buttons to turn the unit on or off.

4 Source Selection: Pressing one of these buttons selects the input source that will be listened to through the receiver. When a source is selected the remote's transport and numeric number buttons will also transmit the commands needed to control that machine.

5 Night Mode: Press this button to activate the "Night" mode, preventing loud playback when the digital modes are in use without altering the dynamic range of the output signal.

6 Delay: Press this button to change the delay for the surround channels when the Surround Mode Menu is on the screen.

7 Digital Audio Input Selectors: Press one of these buttons to select a digital input source. The digital audio source may be the same as, or different analog audio of the selected video source.

8 AM/FM: Press this button to select the AVR75's tuner as an input source. Pressing this button when the tuner is in use will switch between the AM and FM bands.

9 Menu Controls: These buttons control the action of the cursor or the selection of menu items when the receiver is being configured using the setup menus.

10 Select: This button enters settings to the receiver's memory during system configuration.

11 OSD: Press this button to activate the on-screen menu system.

12 Test Tone: Press this button to begin calibration of the output level for each channel. A test signal will immediately be heard from the left front speaker and the **Test** indicator **O** will flash.

13 Channel Select: Press this button to view a status report of the output level for each channel (see figure #9 on page 25). When the Test Tone is audible and the system output levels are being set, pressing this button will advance the channel being adjusted in a clockwise direction to the next channel.

14 Speaker Level Adjust: When setting the system output levels, press these buttons to increase or decrease the output level.

15 Main Volume: These buttons control the unit's volume. Note that all channels are controlled simultaneously.

16 Display: Press this button to turn off all displays and indicators in the Information Display except for a small **Disp** indication in the lower right corner of the display **I**. Press the button again to turn the display back on.

17 Mute: Press this button to temporarily cut the audio output of the receiver. Press it again to return to the previous volume level.

18 Transport Controls: These buttons may be programmed to control the tape or disc motion of the last playback source selected with the **Source Selection** buttons **4**. Use them as you would the Play, Stop, Pause, Record, Reverse Play and Forward Play buttons on any VCR, CD, cassette, DVD or LD remote control. The Reverse Play button **◀** also operates the FM Mode function of the AVR75's tuner.

NOTE: The **● / ||**, **▶** and **■** buttons are also used to control the **PTY**, **AF** and **RDS Display** functions of the tuner (see page 25).

19 Tune/Search & Fast Forward: These buttons may be programmed to have multiple functions, which vary according to the input device selected.

a. When the **TUNER** has been selected, these buttons are used to tune stations.

b. When **CD**, **Tape**, **DVD**, **LD** or **VCR** is the input source, these buttons act as the Fast Scan Forward **▶▶** or Fast Scan Reverse **◀◀** controls.

20 Preset/Disc: These buttons have multiple functions, which vary according to the input device selected.

a. When the **TUNER** has been selected, these buttons will scroll up **▶|** or down **|◀** through the stations that have been programmed in the preset memory.

Remote Control Functions

12

b. When **CD** is selected and the unit is a CD changer, these buttons will change to the next disc **+** or previous disc **-**.

c. When **Tape 1** or **Tape 2** is the input source, and the tape machine is a compatible Harman Kardon dual cassette deck, these buttons will switch between the "A" and "B" sides.

21 Channel/Skip: These buttons have multiple functions, which vary according to the input device selected and the codes programmed from another remote.

a. When **TV**, **Vid 1** or **Vid 2** are selected, they may function as the channel up **▶** or channel down **◀** tuning buttons when programmed with the codes from another unit's remote.

b. When **CD** is selected these buttons act as forward and reverse "Skip" buttons to move to the next track or chapter on the disc.

c. When a compatible Harman Kardon cassette player has been selected as **Tape 1** or **Tape 2**, these buttons move the tape forward **▶** or backwards **◀** to the next selection using the Music Scan feature.

22 Memo: The memo button is used to enter stations to the tuner's preset memory in either the manual or automatic modes. It is also used in the process of clearing the memory. This button also performs the functions of the "*" symbol on compatible equipment.

23 P-Scan: Press this button to automatically scan through the stations preset into the tuner memory. Press the button again to end the scan when the tuner stops at the desired station. This button also performs the functions of the "#" symbol on compatible equipment.

24 Number Keys: These buttons serve as a ten button numeric keypad to enter tuner preset positions. They are also to be used to select channel numbers when **TV** has been selected on the remote, or to select track numbers on a CD, DVD or LD player, depending on how the remote has been programmed. The letters below the buttons are used to enter information for tuner station names.

NOTE: The **0** button has a dual function. It also serves as the **CLEAR** button for use in programming the tuner or clearing the system memory.

25 Surround Mode Selection: Press one of these buttons to select a surround mode for the current listening session.

26 Sleep: Pressing this button when the Sleep timer has previously been activated allows you to view the time remaining before the timer function turns the unit off. When the remote is in the **AM/FM** mode **4**, the Sleep function may also be changed or set by pressing this button so that the **Sleep** and **Memo** indicators **D** **N** blink. Press the **Memo** and **Sleep** buttons within five seconds to set the desired sleep time in the following order:

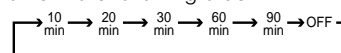

When the desired time is shown in the display press the **Memo** button **15** **22** to enter the time. The unit will go into the Standby mode when the time entered has elapsed.

27 Learn LED: This indicator will illuminate when a button on the remote is being programmed with signals from another remote during the "learning" mode. The light will go out when the signal is received and memorized.

28 Sending LED: This indicator should flash any time a button is pressed to confirm that a command is being sent to the receiver or another unit. If the light is dim or does not illuminate when a button is pressed the batteries in the remote should be replaced.

Installation and Setup

System Installation

After unpacking the unit, and placing it on a solid surface capable of supporting its weight, you will need to make the connections to your audio and video equipment. These steps need to be done only when the receiver is first installed, or when a change is made to the input source equipment.

Audio Input and Output Connections

We recommend that you use high-quality cables when making connections to source equipment and recorders to preserve the quality of the signals.

When making connections to audio source equipment or speakers it is always a good practice to unplug the unit from the AC wall plug. This prevents any possibility of accidentally sending audio or transient signals to the speakers that may damage them.

1. For playback only audio sources, such as a CD player, CD changer, external phono preamp or external digital to analog converter, connect the output jacks of the player to the appropriately labeled inputs on the rear panel **3**.

NOTE: When the source device has both fixed and variable audio outputs it is best to use the fixed output unless you find that the input to the receiver is so low that the sound is noisy, or high that the signal is distorted.

2. When connecting recording devices such as audio cassette recorders, open reel audio tape decks, DCC, DAT or MD, connect the PLAY/OUT jacks of the recorder to the **Tape In** jacks **4 6** on the AVR75. Connect the RECORD/IN jacks on the recorder to the **Tape Out** jacks **3 5** on the AVR75.

3. Connect the output of any digital sources to be used to the appropriate connections on the AVR75 rear panel. Note that the **Optical** and **Coaxial** digital inputs **15 19** may be used with either a Dolby Digital (AC-3) source or the output of a conventional CD or LV player's PCM (SP/DIF) output. The **AC-3 RF** input **20** may ONLY be connected to the special AC-3 RF output of a laser disc player.

4. Assemble the AM Loop Antenna supplied with the unit as shown below. Connect it to the **AM** and **GND** screw terminals **1**.

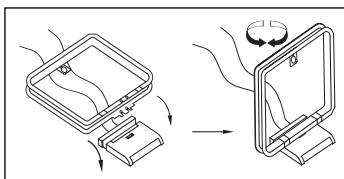

5. Connect an FM antenna to the **FM (75 ohm)** connection **2**. The FM antenna may be an external roof antenna, an inside powered or wire lead antenna, or a connection from a cable TV system. Note that if the antenna or connection uses 300-ohm twin lead cable, you must use the 300-ohm to 75-ohm adapter supplied with the unit to make the connection.

6. Connect the front, center and surround speaker outputs **1 13 14** to the respective speakers.

To assure that all the audio signals are carried to your speakers without loss of clarity or resolution, we suggest that you use high-quality speaker cable. Many brands of cable are available, and the choice of cable may be influenced by the distance between your speakers and this receiver, the type of speakers you use, personal preferences and other factors. Your dealer or installer is a valuable resource to consult in selecting the proper cable.

Regardless of the brand of cable selected, we recommend that you use a cable constructed of fine, multistrand copper with a gauge of 14 or larger. Remember that in specifying cable, the lower the number, the thicker the cable.

Cable with a gauge of 16 may be used for short runs of less than ten feet. We do not recommend that you use cables with an AWG equivalent of 18 or higher due to the power loss and degradation in performance that will occur.

Cables that are run inside walls should have the appropriate markings to indicate listing with UL, CSA or other appropriate testing agency standards. Questions about running cables inside walls should be referred to your installer or a licensed electrical contractor who is familiar with the NEC and/or the applicable local building codes in your area.

Installation and Setup

14

When connecting wires to the speakers, be certain to observe proper polarity. Remember to connect the “negative” or “black” wire to the same terminal on the receiver and the speaker. Similarly, the “positive” or “red” wire should be connected to the like terminal on the AVR75 and speaker.

Note: While most speaker manufacturers adhere to an industry convention of using black terminals for negative and red ones for positive, some manufacturers may vary from this configuration. To assure proper phase, and optimal performance, consult the identification plate on your speaker, or the speaker’s manual to verify polarity. If you do not know the polarity of your speaker, ask your dealer for advice before proceeding, or consult the speaker’s manufacturer.

7. Connections to a subwoofer are made via a line level audio connection from the **Subwoofer Output 11** to the line level input of a subwoofer with a built-in amplifier. If a passive subwoofer is used, the connection first goes to a power amplifier, which will be connected to one or more subwoofer speakers.

Video Input and Output Connections

Video connections are made in a similar fashion to those for audio components. Again, the use of high-quality interconnect cables is recommended to preserve signal quality.

1. Connect the VCR’s audio, video and S-Video OUT jacks to the **Video In** jacks **23 23** on the rear panel. The audio, video and S-Video IN jacks on the VCR should be connected to the **Video Out** jacks **24 27** on the AVR75.

2. Connect the audio and video outputs of a satellite receiver, cable TV converter or television set or any other video source to the **TV** jacks **9**.

3. Connect the audio, video and S-Video outputs of a DVD or laser disc player to the **DVD** jacks **8**.

4. Connect the **TV Mon 25 25** jacks on the receiver to the video, or S-Video inputs, of your television monitor or video projector.

5. As the AVR75 does not mix or change between standard composite video and S-Video signals, both monitor connections must be made if you use both signal systems.

Note: The on-screen menus are visible on the composite video output only.

System and Power Connections

The AVR75 is designed for flexible use with external control components and power amplifiers. These connections are easy to make during an initial installation, or at a later date should you choose to upgrade your system.

Remote Control Extension

If the receiver is placed behind a solid or smoked glass cabinet door, the obstruction may prevent the remote sensor from receiving commands. In this event, an optional remote sensor may be used. Connect the output of the remote sensor to the **Remote Cont. In** jack **21**.

If other components are also prevented from receiving remote commands, only one sensor is needed. They may use this unit’s sensor or a remote eye by running a connection from the **Remote Cont. Out** jack **22** to the Remote In jack on Harman Kardon or other compatible equipment.

External Audio Power Amplifier Connections

If desired, optional external power audio power amplifiers may be used with the AVR75. Connections to these amplifiers are made by using audio interconnect cables connected to both the **Preamp Outputs 10** on the rear panel and the audio input jacks of the external amplifiers.

AC Power Connections

This unit is equipped with two accessory AC outlets. They may be used to power accessory devices, but they should not be used with high-current draw equipment such as power amplifiers. The total power draw may not exceed 50w to each outlet.

The **Switched 15** outlet will receive power only when the unit is on. This is recommended for devices that have no power switch, or a mechanical power switch that may be left in the “ON” position.

Note: Devices with electronic power switches may only go into a Standby mode when plugged in here.

The **Unswitched 16** outlet will receive power as long as the unit is plugged into a powered AC outlet.

Finally, when all connections are complete, plug the power cord into a non-switched 120-volt AC wall outlet. You’re almost ready to enjoy the AVR75!

Remote Control Programming and Operation

This product is equipped with a powerful remote control. As supplied, it will operate the receiver, as well as most CD players and tape decks manufactured by Harman Kardon. If your equipment requires different codes, it may be programmed to copy the codes from most infrared remotes.

Loading Batteries

The life of the batteries for the remote control is about one year in normal operation. If the amber **Sending**  indicator does not flash when remote buttons are pushed, that is an indication that the batteries need to be replaced.

To change the batteries:

1. Remove the back cover by sliding it in the direction of the arrows.

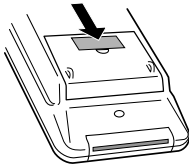

2. Remove the old batteries and insert fresh AAA type cells. Be certain to observe the correct polarity by noting the (+) and (-) marks on both the inside of the case and on the battery cells. It is recommended that both batteries be changed at the same time.

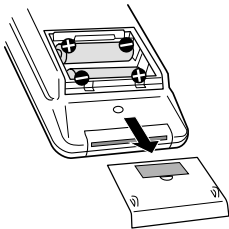

3. Close the cover until it clicks shut.

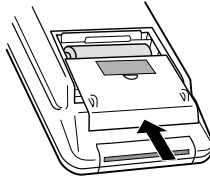

NOTE: It is important that the batteries be replaced within ten minutes after the old batteries are removed to avoid losing any remote codes that have been programmed into the remote's memory.

Remote Control Range

The remote will operate at a range of up to 15 feet from the unit, when the batteries are fully charged. The remote will also operate at an angle of up to 30° to either side of the unit.

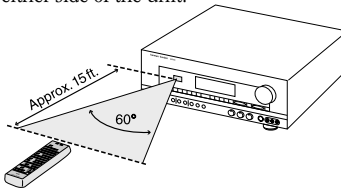

Always point the remote transmitter at the front of the unit when issuing commands. If you find that remote commands are not being received by the remote, it may be necessary to use a remote IR sensor.

Remote Programming

Programmable Keys

Many of the buttons on the remote control may be user programmed to new functions to operate virtually any component in your system. Eleven CANNOT be programmed with a new code, as they control high-level functions of the AVR75. These keys are **Main Power ON**, **Main Power OFF**, and the nine source input keys: **TV, DVD, VID1, VID2, VID3, CD, TAPE1, TAPE2** and **AM/FM**.

Programmable keys are divided into two groups. Some keys may be programmed with a separate function for each of the inputs. Thus, these keys may change their code when the input source is changed. (e.g. The **Play** key may transmit a different code when **CD** is selected as opposed to when **VCR** is selected.) The keys that may be programmed with multiple codes are the following:

All Numeric Keys (**0 – 9**)

Forward Play 

Source Power On

Reverse Play 

Source Power Off

Stop 

Preset Disc 

Record 

Preset Disc 

Pause 

Channel/Skip 

Channel/Skip 

Tune/Search 

Memo

Tune/Search 

P-Scan

Remote Control Programming and Operation

16

All other keys may only be programmed with one remote code. The code contained in these keys remains the same regardless of the source selection.

WARNING: These keys transmit codes that are vital to the operation of the product. It is not recommended that they be programmed with alternative codes, as it may then be impossible to operate certain functions of the receiver.

Night
Delay
RF
Opt
Coax
Select
All Navigation Buttons ◀▶▶▶
All Mode Selectors
*

Display
OSD
Speaker ▲▼
CH Select
Volume ▲▼
Test Tone
Mute

To program the remote, follow these steps. Note that it is not necessary to program all keys, only those that are required to operate the subject device. Keys not programmed will retain the codes preprogrammed at the factory.

1. Slide **Use/Learn 1** switch at the top left corner of the remote to the right so that it is next to **Learn**.
2. If one of the multifunction buttons is being programmed press the source button (e.g. **CD**, **VID1**) you wish to have this function associated with. If you

are programming a single function key, proceed to the next step.

3. Press the button on the remote that is to be programmed. Note that the **Learning 27** LED will illuminate.
4. Place the remote head to head with the remote control whose function is being learned. The two remotes should be no more than 8 inches apart.
5. Press and hold the button on the remote corresponding to the function to be memorized until the **Learning** LED starts to blink. When the LED goes out, release the button on the transmitting remote. The function code has been successfully captured by the remote.

NOTE: If both LEDs flash during a programming operation, it indicates that the remote's memory is full or that the remote codes from the transmitting remote are not compatible with the unit's signal format.

6. Continue to program any additional remote commands required using steps 2 through 5. When you have finished programming the remote, slide the **Use/Learn** switch to the left so that it is in the **Use** position.

Clearing the Remote Memory

In normal operation, codes for a new device may be programmed "over" the codes that have been previously programmed into the remote. It is also possible to clear the memory for individual keys, or for the entire remote. When a memory position is cleared, the remote will return to the original factory preset command.

To clear the memory for a specific individual key location, put the **Use/Learn** button in the **Learn** position. Press the **Main Power Off 3** button and the button to be cleared at the same time. Both the **Sending** and **Learning** indicators will light momentarily. When the lights go out, the memory has been cleared of the user programmed code and returned to the factory preset. Return the **Use/Learn 1** switch to the **Use** position when you are finished.

To clear the remote's entire memory and return all keys to their factory preset commands first put the **Use/Learn 1** switch in the **Learn** position. Then press the **Main Power On** button **3** and confirm that the **Learning** indicator **27** has illuminated. While continuing to press the **Power On** button, press and hold the **Power Off 3** button until the **Learn** indicator goes off for about 3 seconds. It will then blink twice. Then release the two buttons. This indicates that the memory has been cleared of any user programmed commands and that the original commands have been restored. Slide the **Use/Learn** switch **1** back to the **Use** position to return the remote to normal operation.

System Configuration

When all audio, video and system connections have been made, there are a few configuration adjustments to be made. A few minutes spent to correctly configure and calibrate the unit will greatly add to your listening experience.

Speaker Selection

The placement of speakers in a multi-channel home theater system can have a noticeable impact on the quality of sound reproduced.

No matter which type or brand of speakers is used, the same model or brand of speaker should be used for the front left, center and right speakers. This creates a seamless front soundstage, and eliminates the possibility of distracting sonic disturbances that occur when a sound moves across mismatched front channel speakers.

Speaker Placement

Depending on the type of center channel speaker in use and your viewing device, place the center speaker directly above or below your TV or in the center behind a perforated front projection screen.

Once the center channel speaker is installed, position the left and right front speakers so that they are as far away from one another as the center channel speaker is from the preferred listening position. Ideally, the front channel speakers should be placed so that their tweeters are no more than 24" off center from the tweeter in the center channel speaker.

Depending on the specifics of your room acoustics and the type of speakers in use, you may find that imaging is improved by moving the front left and right speakers slightly forward of the center channel

speaker. If possible, adjust all front loudspeakers so that they are aimed at ear height when you are seated in the listening position.

Using these guidelines, you'll find that it takes some experimentation to find the correct location for the front speakers in your particular installation. Don't be afraid to move things around until the system sounds correct. Optimize your speakers so that pans across the front of the room sound smooth, and that sounds from all speakers appear to arrive at the listening position at the same time without delay from the center speaker as opposed to the left and right speakers.

Surround speakers should be placed on the side walls of the room, at or slightly behind the listening position. The center of the speaker should face into the room. The speakers should be located so that the bottom of the cabinet is at least two feet higher than the listeners' ears when in the desired area.

If side wall mounting is not practical, the speakers may be placed on a rear wall, behind the listening position. Again, they should be located so that the bottom of the cabinet is at least two feet higher than the listeners' ears. The speakers should be no more than six feet behind the rear of the seating area.

Subwoofers produce non-directional sound, so they may be placed almost anywhere in a room. Subwoofer placement is highly influenced by room size and shape, and the type of subwoofer used. Follow the instructions of the subwoofer's manufacturer, or experiment with the best location for a subwoofer in your listening room.

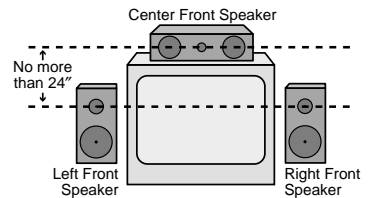

A) Front Channel Speaker Installation with Direct View TV Sets or Rear Screen Projectors

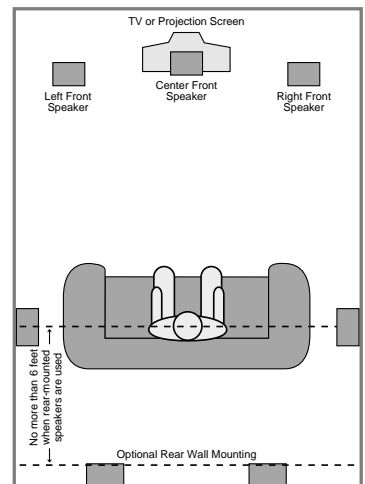

B) The distance between the left and right speakers should be equal to the distance from the seating position to the viewing screen. You may also experiment with placing the left and right speakers slightly forward of the center speaker.

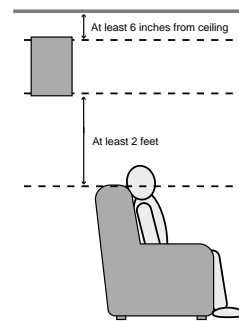

System Configuration

System Setup

Once the speakers have been placed in the room and connected, the final step is to enter the configuration information and balance the speaker output levels. Before proceeding further this is a good time to review the installation section of the manual to make certain that all connections are properly made.

1. Plug the unit into an AC wall outlet and press the **Power** button on the front panel **1**. Note that the ring surrounding the front panel switch will turn red, then green, and the front panel display will illuminate.

2. Install the supplied AAA batteries in the remote as shown on page 15.

3. Turn on the TV connected to the receiver. Select the appropriate video input on the TV.

NOTE: Although the unit will switch S-Video signals, the on-screen menus control system is NOT visible on the S-Video output.

4. Press the **Select** button **10** on the remote to bring the **MAIN MENU** up on your video screen.

5. Press the **▼** button four times until the on-screen cursor **>** is pointing to **SET UP MENU** (see figure #1).

6. Press **Select** **10** to move to the next screen, **SET UP MENU 1** (see figure #2).

7. **SET UP MENU 1** enters the information that tells the AVR75 which type of front and surround speakers will be used. In turn, these settings will determine which speakers receive low frequency (bass) information. For the purposes of establishing proper bass reproduction, use the **LARGE** settings if the speaker being used at any position is a traditional full-range loudspeaker that is capable of reproducing sounds below 100Hz. Use the **SMALL** setting for smaller, frequency-limited satellite speakers that are not able to reproduce sounds below 100Hz. Note that when “small” speakers are used it is advisable to install a separate subwoofer.

8. Enter the information for the **FRONT CH.** speaker by using the **◀** or **▶** buttons **9** on the remote to select the type of front channel speaker that will be used. Press the buttons so that **LARGE** or **SMALL** is highlighted to match the speaker type you will use as described in item #7 above. The **LARGE** setting sends a full-range output to the front left/right speakers, while the **SMALL** setting sends low-frequency sounds to the subwoofer output. When the selection has been made, press the **▼** button once so that the on-screen cursor **>** is pointing to the **SURROUND CH.** line of the display.

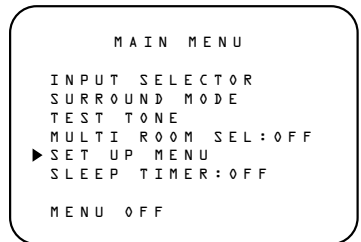

Figure 1

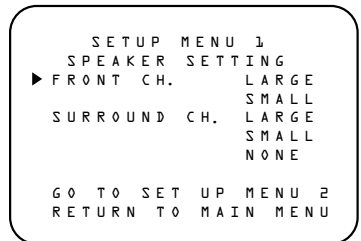

Figure 2

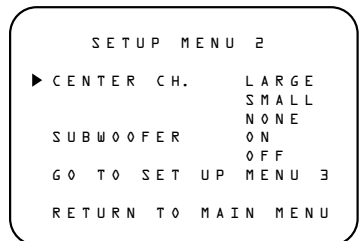

Figure 3

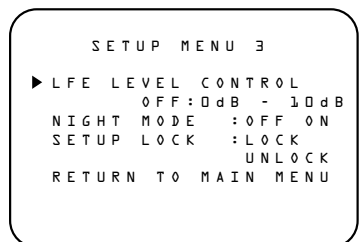

Figure 4

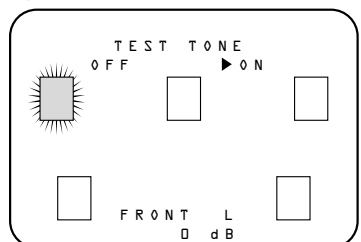

Figure 5

System Configuration

19

9. Enter the information for the **SURROUND CH.** speaker by using the ◀ or ▶ buttons 9 on the remote to select the type of surround channel speaker that will be used. Press the buttons so that **LARGE**, **SMALL** or **NONE** is highlighted to match the speaker type you will use as described in #7 above. The **LARGE** setting sends a full range output to the left/right surround speakers, while the **SMALL** setting sends low-frequency sounds to the subwoofer output or to the front speakers when no subwoofer is selected. If the surround speakers will not be used, the **NONE** setting will send the audio for the surround channels to the front left/right speakers. When the selection has been made, press the ▼ button once so that the on-screen cursor > is pointing to **GO TO SETUP MENU 2**. Press **Select 10** to move to the next menu.

10. At **SETUP MENU 2** (see figure #3), you enter information that configures the AVR75 for the type of center channel speaker to be used, and whether or not a subwoofer is in use. While the on-screen cursor is pointing to **CENTER CH.** press the ◀ or ▶ buttons 9 on the remote to select the correct type of center channel speaker as described in #7. When **LARGE** is highlighted a full-range signal will be sent to the center channel. When **SMALL** is highlighted the audio to the center channel will be cut at 100Hz and low-frequency information will be routed to the subwoofer output or to the front left/right speakers if no subwoofer is selected. When the selection has been made, press the ▼ button once so that the on-screen cursor > is pointing to the **SUBWOOFER** line of the display.

11. At the **SUBWOOFER** line use the ◀ or ▶ buttons 9 on the remote

to highlight **ON** or **OFF**. Select **ON** when an optional external subwoofer is connected to the **Subwoofer Preamp Output 11**. If a subwoofer is not used, highlight **OFF**. In this position all low-frequency sounds (below 100Hz) will be routed to the front left/right speakers. Note that the subwoofer cannot be set to **OFF** when the front speakers are set to **SMALL** in **SETUP MENU 1**. When the selection has been made press the ▼ button once so that the on-screen cursor > is pointing to **GO TO SETUP MENU 3**. Press **Select 10** to move to the next menu.

12. At **SETUP MENU 3** (see figure #4), various control functions will be set. The first item is the **LFE LEVEL CONTROL**. “LFE” is the Low-Frequency Effects channel that is used when Dolby Digital signals are present. The normal setting for LFE is 0dB, but the control may also be set to -10dB for reduced output when an LFE signal is present. The LFE may also be turned **OFF** to reduce low-frequency reproduction. When the LFE level is set, or to bypass this setting, press the ▼ button 9 on the remote to move to the next setting.

NOTE: When the LFE is set to **OFF** the LFE output is cut, and not sent to any other speaker.

13. The next line is the **NIGHT MODE** setting. This feature reduces the input

level for Dolby Digital sources only by 1/3 to 1/4 at their loudest thresholds, preventing unwanted bursts of loud sounds without restricting the dynamic range or volume of other sounds or at less than maximum levels. The feature may be turned **OFF** by pressing the ◀ or ▶ buttons 9 on the remote until **OFF** is highlighted. The Night mode may also be turned on and off at any time by pressing the **Night** button 5 on the remote. When the Night mode is set, or to bypass this setting, press the ▼ button 9 to move to the next setting.

14. The **SETUP LOCK** prevents any of the major control settings from being changed once it is engaged. This feature is set at the factory to **UNLOCK**, so that all settings may be adjusted. If you wish to prevent settings from being easily or inadvertently being changed, use the ◀ or ▶ buttons 9 on the remote until **LOCK** is highlighted. Once the **LOCK** setting is engaged and you exit **SETUP MENU 3**, no changes may be made to any of the Setup menus. To make changes to these menus you must return to **SETUP MENU 3** and use the ◀ or ▶ buttons 9 on the remote until **UNLOCK** is highlighted. When the **LOCK** setting is engaged, the word **LOCK** will appear at the top of the menus to remind you that no changes may be made. When all adjustments have been made, press the ▼ button 9 twice and then press **Select 10** to **RETURN TO THE MAIN MENU**.

At this point you may wish to adjust the delay time settings, although it is

System Configuration

best to use the factory settings for initial listening sessions. See the Advanced Features section later in this manual for information on delay settings.

The remaining item to be adjusted before normal use of the AVR75 is adjustment of the output levels. Correct adjustment of these settings is critical to proper operation of the receiver in all surround modes, and particularly when Dolby Digital sources are being played.

1. To set the output levels press the **Select** button **10** to call up the main menu (see figure #1) if it is not already on the screen, and then press the **▼** button **9** until the on-screen cursor is pointing to **TEST TONE**. Press **Select** **10** to move to the **TEST TONE** menu.

2. When you press **Select** you will immediately hear a test noise from the front left speaker. The on-screen display will change to a graphic representation of each of the speakers in your room, with one speaker position blinking (see figure #5). That speaker is the one whose level is being set.

NOTE: This procedure will only operate if the AVR75 is in the **PRO LOGIC, AC-**

3, MOVIE or DOLBY 3 STEREO modes. If the test tone cannot be selected, check to see which surround mode is indicated in the front panel display. If it is not one of the modes mentioned above, select one of the correct modes using the **Mode Selectors** **25**, and then move the cursor to **TEST TONE** to restart the procedure.

3. While seated in the primary listening position, you should hear a test noise signal from the left front speaker. You may leave the volume setting where it is, or raise it to an appropriate level using the **Speaker ▲** or **▼** buttons **14** on the remote. For a more precise calibration, we recommend that you use a sound pressure level meter.

4. Press the **▶** or **CH Select** button **9 13** on the remote. Note that the sound should now come from the Center Channel speaker if one is installed, and the icon for that speaker will flash on the screen. Use the **Speaker ▲** or **▼** buttons **14** on the remote to change the level of the test noise so that it appears to be equal in level to the Front Left speaker.

5. Press the **▶** or **CH Select** button **9 13** again, and repeat the procedure for the Front Right, Surround Right and

Surround Left channels. Each time, use the **Speaker ▲** or **▼** buttons **14** on the remote to change the volume level so that all speakers match, and the **▶** button **9** to move to the next channel.

NOTE: This test also serves as an opportunity to verify that all speakers are properly connected. If the sound from a speaker location does not match the location shown on the video and front panel displays, turn the AVR75 off and check the speaker wiring to make certain that the speaker is connected to the correct output terminals.

6. When all speakers appear to have an equal volume, press the **◀** button **9** on the remote and then **Select** **10** to complete the procedure.

NOTE: You may also check the output levels at any time by pressing the **Test Tone** button **12**. When the on-screen display is also activated by pressing **OSD** **11**, you will see the speaker icons and level information superimposed on your video screen. Follow the instructions in steps 1 through 6 above to calibrate the system, and press the **Test Tone** button **12** again to cancel the test.

CONGRATULATIONS! You have completed a basic setup and you are now ready to enjoy the finest in home theater and music listening enjoyment.

Basic Operation

21

Once the input source, speaker and antenna connections have been made, and the system has been configured, the receiver is ready for operation. Note that some controls are duplicated on both the front panel and the remote control, while others appear on one or the other, but not both.

Power Switch

To turn the AVR75 on for the first time, press the front panel **Power** button **1**.

When you press the **Power** button note that the LED indicator surrounding the switch will momentarily turn red, then green indicating that the unit has been turned on. If the unit is connected to a TV set a brief status report (see figure #6) of the AVR75's settings will momentarily appear.

Once the unit has been turned on with the front panel switch it may then be placed in a Standby mode for future use using the **Main Power On** **3** button on the remote. Note that the remote power will NOT operate unless the **Power** button has first been manually depressed.

When the AVR75 is turned off using the remote control it is placed in a STANDBY mode, and the Standby LED surrounding the **Power** switch will illuminate in amber. The AVR75 may be turned on by pressing either the **Main Power On** button **3** or any of the **Source** buttons on the front panel **2 4 5 7 8 10 11**.

NOTE: When the AVR75 is in the Standby mode, and the amber LED around the **Power** switch is illuminated, it is NOT disconnected from the AC main power.

To turn the AVR75 totally off, press and release the **Power** button **1** until the LED surrounding the switch goes out.

Source Selection

To select or change the input source, press one of the **Source** buttons on the front panel **2 4 5 7 8 10 11** or one of the **Source** buttons on the remote **4**.

Each time the source is changed a message (see figure #7) will appear briefly if the on-screen display is activated confirming the new selection.

To listen to one source while you watch another, first select the video source, and then select the desired audio source.

NOTE: When the unit is in "Standby" mode, pressing any of the source buttons will turn on the unit.

The video source will be shown next to the word **VISUAL** in the **Visual Indicator P** in the **Information Display 27**. The audio source, which may be the same or different than the video source will always be shown in the **Main Information Display 1**.

Volume Control

The AVR75's volume is controlled using either the front panel **Volume** knob **26** or the **Volume** buttons **15** on the remote.

If the volume control is set too high, a speaker overload may activate the unit's protective circuitry. This will cut the output to the speakers and change the LED surrounding the power switch to a red color. To clear the problem, turn the unit off for a few seconds, and lower the volume before turning it back on. If the problem re-occurs, turn the unit off and consult your dealer or an authorized service center for advice.

NOTE: Unlike conventional mechanically driven volume controls, this receiver's volume is set using digital devices. This means that the volume knob has no firm stopping point at either end of its rotation. Depending on the speed with which the knob is turned, it is normal for as many as three complete rotations to be required for full travel from the loudest setting to the softest.

When the volume is adjusted the change will be indicated by an on-screen display (see figure #8). The word **MASTER** will also appear in the main portion of the **Information Display 27**, followed by a two-digit number. The number indicates the variation from the reference point established when the output levels are set.

Surround Mode Selection

One of the most important features of the AVR75 is its ability to reproduce a full multichannel surround soundfield from Dolby Digital sources, analog matrix surround encoded programs, and standard stereo programs. In all a total of seven listening modes are available.

Selection of a surround mode is based on personal taste, as well as the type of program source material being used. For example, motion pictures bearing the logo of one of the major surround encoding processes, such as Dolby Digital, Dolby Surround, DTS+ Stereo or UltraStereo++ may be played in either the Dolby Digital, Dolby Pro Logic or Movie Surround depending on the source material. TV or radio broadcasts of programs in surround should normally be played back in the Dolby Pro Logic or Movie Surround modes. Other mode selections are described elsewhere in this manual.

Basic Operation

22

NOTE: Once a program has been encoded with surround information, it retains the surround matrix as long as the program is broadcast in stereo. Thus, movies with surround sound will carry surround information when they are broadcast via conventional TV stations, cable, pay TV and satellite transmission. In addition, a growing number of made-for-television programs, sports broadcasts, radio dramas and music CDs are also recorded in surround sound. You may obtain a list of these programs and discs from the Dolby Laboratories web site at www.dolby.com

Surround modes may be selected in one of three ways.

From the front panel, use the **Mode ▲** or **Mode ▼** buttons **12** to scroll through the list of modes. The selected mode will appear in large letters in the front panel display, and in a two-line reminder on the video screen. Once the selection is made, the mode will continue to appear in a smaller indicator **B** at the bottom of the front panel display (see figure 9).

From the remote, modes may be selected by simply pressing the button **25** that corresponds to the desired mode.

Modes may also be selected using the on-screen display. Press **Select 10** on the remote to display the **MAIN MENU**. Then press **▼ 9** so that the on-screen cursor is next to **SURROUND MODE**. Press **Select 10** again to move to the next menu.

At the Surround Mode Menu, press the **◀** or **▶** buttons **9** until the desired mode name appears on the screen. Press **▼** until the on-screen cursor **>** is next

to **RETURN TO MAIN MENU** and press **Select 10**. At the main menu select **MENU OFF** and press **Select 10** to exit the menus.

A different mode may be selected for audio and video sources. Once a mode has been selected, it will be attached to those sources in memory. Thus, you may select **PRO LOGIC** as the mode for one video source and **HALL** for another. After the initial selections are made, the unit will automatically return to your preferred mode for each type of input whenever it is chosen.

Digital Audio Sources

When the source is connected to the AVR75 and playing digital audio information, first select it using the front panel or remote input selectors, and then press the appropriate digital input using the **Digital Input Selectors 7 9** on the remote or front panel. Depending on the type of digital source in use, the **AC-3** indicator **A** will light when a Dolby Digital signal is present, or the **PCM** indicator **Q** will light when a standard two-channel S/P-DIF-type digital signal is present.

Once a Dolby Digital signal is detected the unit will automatically switch to the Dolby Digital mode. When a PCM digital source is detected you may select any of the surround modes except Dolby Digital.

NOTE: The Dolby Digital mode should not be selected when PCM digital or analog signals are present. If the Dolby Digital mode is selected when an AC-3 signal is not detected, the AVR75 will default to the **STEREO** mode.

For information on using Digital Audio Sources, see the Advanced Features section of this manual.

IMPORTANT NOTE: Many people incorrectly presume that sound should always be heard from the surround channels. In reality, it is normal for the surround channels to operate occasionally, and often to be silent. Movie directors and sound mixers typically use these channels only when needed to create an effect or establish ambience. Artificially increasing the volume level to the surround channels may destroy the illusion of surround audio and add unwanted noise to your system.

Tuner Operation

The AM/FM tuner is extremely flexible, and offers a number of options. The following instructions will enable you to take advantage of the tuner's many features.

To select tuner operation, press the **AM/FM** button **2** on the front panel, or the remote **8**. Press the button again to select the desired frequency band if required.

Up/down tuning is accessible by pressing the **Tune** button **23** on the front panel either up **▲** or down **▼** or the **◀◀ TUNE/SEARCH ▶▶** buttons **19** on the remote. Pressing these buttons once increases or decreases the station frequency by one step. Holding the buttons down quickly scans for the next station. Holding the tune buttons for a few seconds and then releasing them will change the tuner to the next station with an acceptable signal.

Basic Operation

23

When manually tuning stations, observe the **Signal Level** indicator **R** and the **Tuned** indicators **L**. The more bars that are visible on the **Signal Level** indicator, the stronger the signal and the better the station will sound. A station is properly tuned when the **Tuned** indicator is illuminated.

Tuner Mode

Pressing the **Mode** **17** or **FM Mode** **18** button on the front panel or remote selects how a station will be received. When the button is pressed so that the **Auto** indicator **M** is lit, stations broadcasting in stereo will be received in stereo. You may note stereo broadcasts by observing that the **Stereo** indicator **K** will illuminate. When the **Mode** button **17** **18** is pressed until the **Auto** light **M** goes out, all stations will be received in a monaural mode regardless of the method of transmission.

NOTE: When a station is broadcasting in stereo, but has a weak signal level, the reproduction may not be acceptable. In this case, select the Auto Off mode, as monaural reception is less susceptible to noise in weak reception areas.

Tuner Presets

There are thirty preset positions that may be used to store your favorite stations in any order. These may be used to memorize the station's frequency, reception mode and the station's name. Stations may be preset automatically or manually, and then recalled in a variety of ways.

Automatic Station Preset Selection

This process automatically scans the AM and FM bands and enters all stations with proper signal strength into the memory. To automatically preset the tuner's memory, follow these steps:

1. Select the tuner as the unit's input by pressing the **AM/FM** button **2** **4**.
2. Using the **Tune** buttons **23** **19**, select the first station you wish to preset at the low end of the AM or FM band.
3. Start the automatic tuning preset by simultaneously pressing **Memo** and **Tune** **▲** on the front panel **15** **23**. The station tuned in step #2 will be entered into the tuner's memory as **PRESET 1**. The **Memo** indicator **N** will flash. The display will show increasing frequencies to indicate that the auto scan is in progress.
4. Each time the tuner finds a station the scanning will pause and the station will be played for five seconds. During this time you have the following options:
 - a. To enter the station in the next open memory position, no action is needed. After five seconds the tuner will enter the station and the preset number will be visible at the far left side of the main information display.
 - b. The frequency band may be changed by pressing the **AM/FM** button **2** **8**.
 - c. If the tuner is scanning FM stations, the **Mode** may be changed from **Auto** to mono by pressing the **Mode** button **17**.
 - d. If you do not wish to enter the current station into the preset memory, press the **Tune** **▲** button **23** **19** on the front panel or remote.

5. After the desired action is completed, or five seconds elapse, the tuner scan will continue. The operation will stop automatically when all 30 preset positions are filled or when both frequency bands have

been completely tuned, whichever comes first. To stop the automatic preset process at any time press the **Clear** button **16** or any input selection button.

Manual Tuner Preset

Stations may be manually entered into the tuner's memory in any order. Manual entry is performed from the remote control only.

1. Tune to the desired station as outlined in the Tuner Operation Section.
2. Press the **Memo** button **15** **22** and note that the **Memo** indicator **N** will flash.
3. While the indicator is flashing for the next 5 seconds, enter a number from 1 to 30 using the number buttons on the remote **24**. Any number may be used, but if another station has already been programmed into the location number selected, the previous setting will be lost.
 - a. To enter a single digit memory location, press **0** before the number, or enter the number and wait a few seconds.
 - b. If an invalid number (other than 1–30) is entered, the display will flash to alert you that the entry is invalid and it will return to the previous frequency display.
4. When the preset memory has been properly programmed the **Memo** indicator **N** will stop blinking.

Station Name Preset

In addition to identifying stations by their broadcast frequency, each preset station may be assigned a name using alphanumeric characters. This enables you to identify a station by its call letters, program format, or any other five character phrase.

Basic Operation

24

1. Tune to the desired preset station.
2. Press and hold the **Memo** button **15** **22** for more than three seconds.
3. Note that a character on the left side of the main information display will start to blink.
4. Enter the first character of the name using either the front panel **Tune** **▲** or **▼** buttons **23** or the alphanumeric buttons **24** on the remote.

A. To use the front panel buttons simply press and hold **Tune** **▲** **23** button until the desired letter or number appears. Note that the upper case alphabet will appear, followed by the numbers **1** through **0**, and then a **_** indicating a blank space. Tapping the button will advance the display one character at a time; holding it down will move the display quickly. If you pass by the desired character, use the **Tune** **▼** **23** to move the display in reverse.

After entering the first character, press **Memo** **15** to move to the next position and note that the next digit will blink. Use the same procedure outline above to enter a character.

When you have entered a digit or “blank” in all five spaces, press and hold the **Memo** button **15** for a second to confirm the entry

B. To use the remote for character entry, press the button corresponding to the desired letter or number. Press it once to enter the first printed letter, twice for the second, three times for the third and four times for the number. Press the “**9**” button once to enter a blank space. (For example, press the “**ABC**” button once to enter an “**A**,” three times for a “**C**” and four times to enter a “**1**.”)

Use the **Memo** button **22** to move to the next digit position. When all five spaces have been filled, press and hold the **Memo** button again for a second to confirm the entry.

Once a station name has been attached to a preset position, the station’s frequency will appear briefly when the unit is tuned to that station. After a few seconds the preset name will appear in the display.

Tuning Preset Stations

Stations preset into the tuner’s memory may be recalled in a number of ways.

1. To recall a station directly enter a number from 1 to 30 using the number buttons on the remote **24**.
 - a. To enter a single digit memory location, press **0** before the number, or enter the number and wait a few seconds.
 - b. If an invalid number (other than 1–30) is entered, that number will flash to alert you that the entry is invalid.

2. To scan through the list of preset stations, press the **P-Set** **▲** or **P-Set** **▼** button on the front panel **20** or the **◀▶** buttons **21** on the remote. Press once to move up or down through the memory presets one by one, or press and hold the button to quickly scan through the list of stations.

3. To automatically review each station in the memory, press the **P-Scan** button **23** **22**. Note that the **P-Scan** indicator **G** will blink.

- The tuner will move up through the list of stations, pausing to play each for five seconds. Note that preset numbers where no station has been programmed will be skipped.

- When the desired station is reached press **P-Scan** **23** **22**.

Clearing Preset Stations

Once stations are programmed into the preset memories, it is possible to remove them individually or as a group.

To remove a single station from the memory:

1. Recall the station by pressing the buttons on the remote corresponding to the station’s memory location.

2. Press the **Memo** button **15** or **22** and observe that the **Memo** indicator **Q** will blink.

3. While the indicator is blinking, press the **Clear** button **16** within five seconds. The word **CLEAR** will show briefly to confirm that the memory position has been cleared.

To clear *all* memory locations for the tuner, as well as all volume level and surround mode memories:

1. Press the front panel **Memo** **15** and **Clear** buttons **16** at the same time.

NOTE: When a complete memory clear is performed the AVR75 will turn off and then on as part of the process. After clearing the memory it is necessary to reset all stations and set up parameters.

On-Screen Display

26

Surround Mode and Delay

When the surround mode is changed or the delay timing is adjusted, a message will appear at the bottom of the video screen (see figure #10). The top line is the surround mode, the bottom line is the delay time for that mode.

Input Selection

When the source input is changed, this message will appear (see figure #7). The top line is the audio input source, the middle line is the video input source and the bottom line is the digital source in use, if any. Remember, when choosing an input, select the video source first, and then the audio source if a split input/simulcast listening session is desired.

Master Volume

When the volume is changed, a horizontal scale will briefly appear at the bottom of the screen with the volume level (see figure #8).

Mute

When the unit is placed in audio mute, the word **MUTE** will appear in the upper right corner of the screen as a reminder that the volume has been cut (see figure #11).

Sleep Timer Function

Pressing the **Sleep** button **25** displays the **SLEEP TIMER** menu (see figure #12) which shows if the timer is on and the number of minutes remaining before the unit shuts down. To activate the Sleep Timer function you must go to the Sleep Timer menu that is accessed through the Main menu system (see page 27 for additional information).

On-Screen Display Function

If you do not wish to have the On-Screen Displays appear, press the **OSD** button **11 13** twice. A reminder message will appear on the screen for a few seconds (see figure #13), and the displays will then be canceled until they are once again activated.

Using The On-Screen Menus for System Control

Besides conveying status messages, the On-Screen Display system may also be used as a means of controlling the operation of the unit. To operate the unit through the on-screen menu system, start by pressing **Select 10** on the remote to bring up the Main Menu (see figure #1). Then, use the up/down navigational arrow keys **▲** and **▼ 9** to move the cursor to the menu for the operation you wish to control or adjust. Press **Select 10** to choose a menu, and then use the left/right navigational arrow keys **◀** and **▶ 9** to view the choices in that current option. Finally, when the desired choice appears, press **Select 10** to enter the choice and return to the **MAIN MENU**. To exit from the Menu Control System, press **▼ 9** until the on-screen cursor **>** is pointing to **MENU OFF** and press **Select 10**.

The following functions of the AVR75 may be controlled through the Menu Control System:

INPUT SELECTOR: At this menu you may change the audio or video input by using the **▲** or **▼** buttons **9** to position the on-screen cursor **>** next to

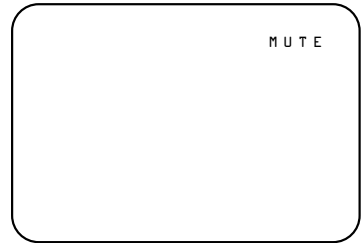

Figure 11



Figure 12

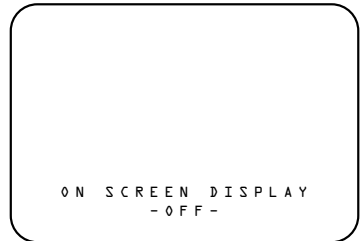

Figure 13

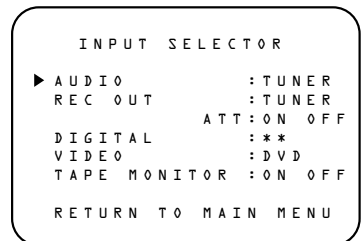

Figure 14

On-Screen Display

27

AUDIO or VIDEO. When either input type is highlighted in reverse video use the ◀ or ▶ buttons **9** to select the source you wish to listen to or view. Remember that the video source should be selected first when you wish to watch one source and listen to another.

To select a digital audio input use the ▲ or ▼ buttons **9** to position the on-screen cursor > next to **DIGITAL**. Press **Select 10** and note that the word **DIGITAL** will be highlighted in reverse video. Then use the ◀ or ▶ buttons **9** to select the desired digital source. Note that when any digital source is selected, the audio source will indicate **.

You may also use this menu to turn the attenuation, or ATT, function on or off for a source by moving the cursor to the **ATT** line and using the ◀ or ▶ buttons **9** to select **ON** or **OFF**. When the ATT function is enabled the input level is reduced to prevent overloading the input circuits.

SURROUND MODE: At this menu (see figure #15) you may change the surround mode by using the ▲ or ▼ buttons **9** to position the on-screen cursor > next to **MODE** and using the ◀ or ▶ buttons **9** to select the desired mode. To change the delay time position the cursor next to **SURROUND CH** and then use the ◀ or ▶ buttons **9** to select desired delay time for the surround channels. Note that an adjustment for the delay time of the center channel is possible only in the Dolby Digital mode.

TEST TONE: At this menu you may adjust the front and surround speaker output levels. For information on this procedure, refer to the System Configuration section of this manual.

SET UP MENU: For information on using the Setup menus, refer to the System Configuration section of this manual.

SLEEP TIMER SET: This enables you to set the sleep timer, which will place the unit in a standby mode after a set period of time. To reach this menu, press the ▲ or ▼ buttons **9** to position the on-screen cursor > next to **SLEEP TIMER** and press **Select 10**. At the next screen, the **SLEEP TIMER SET** menu (see figure #16) the cursor will be next to **TIMER SET**. Use the ◀ or ▶ buttons **9** to select the amount of time before turn off and note that the time will blink. Press the ▼ button so that the on-screen cursor >

is next to **TIMER OFF ON**. Use the ◀ or ▶ buttons **9** to highlight **ON** and press **Select 10**. The time figure will stop flashing indicating that the timer has been started. Press ▼ one more time so that the cursor is next to **RETURN TO MAIN MENU** and press **Select 10**. Note that when the **MAIN MENU** returns to the screen the time figure will appear next to the words **SLEEP TIMER**. You may check the time remaining before shut off at any time by pressing the **Sleep** button **26** on the remote and viewing the front panel or on-screen display (see figure #12).

Position the on-screen cursor > next to **MENU OFF** at any time to exit the menu system and return to normal operation.

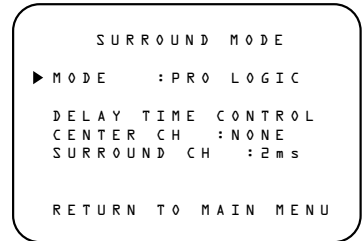

Figure 15

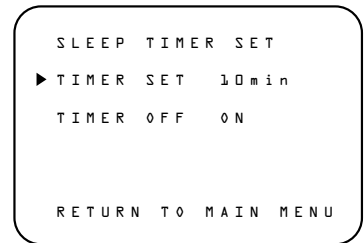

Figure 16

Advanced Features

28

In addition to basic audio functions, this receiver is capable of audio/video dubbing and a wide range of surround modes. Advanced digital decoding and signal processing provides specialized surround modes that are compatible with virtually all types of music software and movie soundtracks.

Audio Tape Dubbing

The input directed to the audio and video record outputs **3 5 24 27** is normally the source currently selected for listening through the AVR75. If you are using a tape recorder or cassette deck with three heads and wish to listen to the “off tape” playback to verify the recording, press the front panel **T-Mon** button **5** or the **Tape 1** **4** button on the remote until the red light over **T-Mon** on the front panel illuminates. You will then hear the source as it is being recorded and played back through your tape machine. The source will be verified in both the front panel and on-screen displays. Note that the video surrounding the word **AUDIO** will turn white to indicate that you are in the Tape Monitor mode.

Audio/Video Simulcast Operation

It is possible to watch and listen to, or record the video from one source along with the audio from a different input. This is useful in the case of musical programs where the sound is being broadcast via FM, or for sports events where you wish to have the picture from a TV station, but the play-by-play from a radio station.

For simulcast operation first select the video source input using the input selection buttons on the remote control or front panel **8 10 11 4**. Next, select the audio source **2 4 5 7 4**. Note that the on-screen menu display will show the

split sources (see figure #7). The front panel display will show the audio source in large letters in the main portion of the **Information Display J**, while the video source will appear in smaller letters next to the **Visual** indicator **P**.

TV Auto Function

With the increasing sophistication of today's home entertainment systems, it often takes numerous remote controls to turn on all components in a system. This receiver's unique “TV Auto On” function greatly simplifies that task and reduces the actions needed to bring your entire system to life.

If you are using a TV or projector that has a video output, connect the TV's audio and video outputs to the rear panel of the AVR75 **9**. Once those connections have been made and the feature is turned on, the AVR75 will automatically turn on whenever the TV set is on, thanks to a video-sensing circuit in the AVR75. This eliminates the need to turn the unit on separately from the TV.

As long as the TV is on and feeding a video signal, the AVR75 will remain on. If no other input source is selected and the TV is turned off, the AVR75 will turn off approximately five minutes after the TV set.

This feature is turned off in the AVR75's factory configuration and must be turned on using the following steps:

1. Press the front panel **Mode** **▲** button **12**.
2. While holding the Mode button, press the **TV** button **8** for at least 5 seconds until the **Main Information Display J** display reads **TV AT OFF**.

3. Release both buttons and immediately press the **TV** button **8** again until the display reads **TV AT ON**.

If you select another input, such as CD or the AM/FM tuner after the unit has turned on, it will remain on even if the TV is turned off. You must then turn the receiver off using the front panel or remote **Power** buttons **1 3**.

NOTE: The TV Auto On Function will only respond to conventional video signals. It will NOT operate with S-Video.

If, at some future point you wish to disable this feature, follow the steps outlined above but press the **TV** button **8** as shown in step #3 so that the display reads **TV AT OFF**.

Delay Time Adjust

One aspect of the surround modes is the delay of audio signals between the front speakers and the rear speakers. Each surround mode is factory preset with a specific delay time, but it is possible to individually adjust the delay timing to custom tailor the sound to your individual taste and the acoustic conditions in your listening room or home theater.

The factory setting is appropriate for most rooms, but some installations create an uncommon distance between the front and surround speakers that may cause the arrival of front channel sounds to become disconnected from surround channel sounds.

To resynchronize the front and surround channels, follow these steps:

1. Measure the distance from the listening/viewing position to the front speakers.
2. Measure the distance from the listening/viewing position to the surround speakers.

Advanced Features

3. Subtract the distance to the surround speakers from the distance to the front speakers.

a. When setting the delay time for the Dolby Digital surround mode, the optimal delay time is the resulting figure. For example, if the front speakers are ten feet away and the surround speakers are five feet away, the optimal delay time is figured as $10-5=5$. Thus, in this example, the delay should be set at five milliseconds.

b. When setting the delay time for an analog surround mode (Pro Logic, Hall, Movie or Matrix) take the result of the subtraction and add 15 to obtain the optimal delay time. For example, if the front speakers are ten feet away and the surround speakers are five feet away, the optimal delay time is figured as $10-5+15=20$. Thus in this example, the delay should be set at twenty milliseconds.

The Dolby Digital mode also provides a separate setting for the center channel delay mode, since the discrete nature of Dolby Digital signals makes the location of the center channel speaker more critical. To set the delay for the center channel, measure the distance from the preferred listening position in the center of the room to both the center channel speaker and either the left or right speaker.

If the distances are equal no further adjustment is required and the center delay should be set to zero. If the distance to the front speakers is greater than the distance to the center speaker you may wish to reposition the speakers by moving the front left/right speakers closer to the listening position or the center speaker further away from the listening position.

If repositioning of the speakers is not possible, adjust the center delay time so that you add one millisecond of center channel delay for each foot that the distance to the center speaker lags behind the front speakers. For example, if the front left/right speakers are each 10 feet from the listening position and the center channel speaker is 8 feet away, the delay is figured as $10-8=2$, suggesting an optimal center delay of 2 milliseconds.

The factory settings for the delay times are shown in the chart on page 31. If the use of the formulas described above or your own experimentation and preferences suggest that the delay time be changed, the adjustment is made from the **SURROUND MODE** menu.

Reach the menu by pressing **Select** **10** and then pressing the **▼** button **9** once so that the on-screen cursor **>** is next to the **SURROUND MODE** line and then press **Select** again. The **SURROUND MODE** menu (see figure #15) will then appear. If you wish to change the surround mode before proceeding, use the **◀** or **▶** buttons **9** until the desired mode is highlighted in reverse video. Next press the **▼** button so that the cursor is next to **CENTER CH** or **SURROUND CH**. (Note that center channel delay may only be adjusted in Dolby Digital mode.) Press the **▶** button **9** until the desired time is highlighted in reverse video and then press **▼** until the cursor is next to **RETURN TO MAIN MENU** and press **Select** **10**. Other adjustments may now be made, or move the cursor to **MENU OFF** and press **Select** to exit the menu system.

Digital Audio Playback

Dolby Digital

Dolby Digital (also known as AC-3) is the latest advancement in surround sound technology, delivering up to five full-range surround channels (left, center,

right, left surround and right surround) plus a special dedicated Low-Frequency Effects (LFE) channel. This represents a major advancement over traditional analog surround in that each surround channel is fully discrete and capable of full bandwidth reproduction. Dolby Digital is available on DVD and LV discs, and it will be a part of the new high definition television (HDTV) system when digital broadcasting begins in 1998. Dolby Digital for the home is based on the same system used to deliver digital audio soundtracks in movie theaters, enabling true cinema reproduction in your home.

To utilize the Dolby Digital mode you must have a digital source properly connected to the AVR75. The RF digital output of a laser disc player should be connected to the **AC-3 RF** jack **20** on the rear panel. Note that this jack is for use *only* with the RF output from an LV player and should not be connected to any other audio, video or digital device. Digital datastream outputs from DVD players, HDTV receivers and CD players should be connected to the **AC-3/PCM Optical** or **Coaxial** inputs on the rear panel **18 19**. In order to provide a backup signal and a source for recording, the analog outputs provided on digital source equipment should also be connected to their appropriate inputs on the AVR75 rear panel. (e.g., connect the analog stereo audio output from a DVD to the **DVD** inputs **8** on the rear panel when you connect the digital outputs).

When playing back a digital source, first select the input using the remote or front panel controls **4 4 8 10 11**. Next select the digital source by pressing the appropriate **Digital Input** button **9 7**. When the digital source is playing, the AVR75 will automatically detect

Advanced Features

30

if it is a multichannel Dolby Digital source or a conventional PCM signal, which is the standard output from CD players. An indicator will light in the Front Panel Information Display to confirm the digital signal is **AC-3** **A** or **PCM** **C** and if the source is **RF**, **Optical** or **Coax** **C**.

When an AC-3 source is playing the AVR75 will automatically switch to the Dolby Digital surround mode. It is important to note, however, that not all AC-3 sources are encoded with the full complement of five channels plus LFE. When an AC-3 source is playing the **Main Information Display** **I** will change to show the input source (**RF**, **Optical** or **Coax**) and then the surround mode will briefly be displayed (**DOLBY AC-3**). After these displays appear briefly, the display will show the selected analog source and the digital surround mode as follows:

3/2-1: This message appears when a full complement of Dolby Digital signals is present: 3 front channels (left, center and right), 2 surround channels (surround left and surround right) and "1" channel, which is the dedicated Low Frequency Effects (LFE) channel.

3/1: This message indicates the AC-3 system is decoding a standard Dolby Pro Logic signal with left, center and right front channels and a single mono surround channel.

2/0: This message indicates that the AC-3 system is decoding a traditional two-channel stereo signal and that no center, surround or LFE signals are present.

Night Mode

A special feature of Dolby Digital is the Night mode, which enables AC-3 input sources to be played back with their full range while reducing the minimum peak level by 1/4 to 1/3. This prevents abruptly loud transitions from causing disturbances without reducing the impact of the digital source. The Night mode is available only when AC-3 signals with special data are being played.

To engage the Night mode, press the **Night** button **6** **5** on the front panel or remote and note that **Night** indicator **E** will illuminate. The Night mode may also be turned on through **SETUP MENU** **3**.

IMPORTANT NOTES ON DOLBY DIGITAL PLAYBACK:

1. When the playback unit is in a pause, fast forward or chapter search mode the digital audio data may momentarily stop, causing a **NO DATA** message to be displayed. This is normal and does not indicate a problem with either the AVR75 or the source machine. The AVR75 will return to Dolby Digital/AC-3 playback as soon as the data is available when the machine is in a standard play mode.

2. If a digital source is being played and you switch to another input the AVR75 will revert to the analog input when you once again select the prior source. For example, if a DVD is playing with coax digital audio and you switch to TV and then back to DVD, the DVD's analog audio will play when you return to that source. The digital input **MUST** be selected each time you wish to use it, even if it was in use the last time that source was playing.

3. The AVR75 will decode digital audio sources with a sampling frequency of 32kHz, 44.1kHz and 48kHz. Although this will enable it to decode virtually all DVD movies and HDTV sources, it is possible that some digital sources may not be compatible with the AVR75.

4. The AVR75 will automatically detect most Dolby Digital and PCM digital audio sources and switch to the proper surround mode. It is possible, however, that future source equipment that could not be anticipated at this time, may require manual surround mode selection using the **Surround Mode Selectors** **12** **25**.

PCM Audio Playback

PCM (Pulse Code Modulation) is the non-compressed digital audio system used for conventional compact discs and non-AC-3 laser discs. The digital circuits in the AVR75 are capable of high-quality digital-to-analog decoding, and they may be connected directly to the digital audio output of your CD or LV player.

Connections should be made to the **AC-3/PCM Optical** or **Coaxial** inputs **18** **19** on the rear panel, using whichever input is not occupied by an AC-3 source such as a DVD player.

To listen to a PCM digital source first select the analog input (e.g., CD) and then press the desired **Digital Input** button **9** **7**. Indicators will light to confirm that **PCM** data is being received **C** and if the **Optical** or **Coaxial** input **C** is the source. The **Main Information Display** **I** will show both the last analog source and the type of digital input in use (e.g., **CD/COAX**).

Advanced Features

The first time a PCM source is played the AVR75 will automatically select the Stereo mode, but you may then select any surround mode desired.

Recording When Digital Sources Are In Use

Since the record outputs of the AVR75 are traditional two-channel stereo, the multichannel outputs of a Dolby Digital signal may not be recorded. When any

digital signal is being played, the accompanying analog audio signal is sent to the **Tape Out** and **VCR Out** jacks **Ⓔ** **Ⓕ** **Ⓖ** **Ⓗ** **Ⓙ**. The video source being output is the last selected video input shown in the **Visual** indicator **Ⓟ**.

Surround Mode Chart

<i>MODE</i>	<i>FEATURES</i>	<i>DELAY TIME RANGE</i>
DOLBY DIGITAL	This mode is used only when the source material is encoded with Dolby Digital (AC-3) data. It provides up to five separate main audio channels and a special dedicated Low-Frequency Effects channel. Use this mode with DVD, LV or HDTV sources featuring Dolby Digital playback.	Center: 0 ms – 5 ms Surround: 0 ms – 15 ms
DOLBY PRO LOGIC	Dolby Pro Logic is the standard mode for surround sound decoding. It uses information encoded in a two-channel stereo recording to produce four distinct channels: Left, Center, Right and Surround. Use this mode for accurate reproduction of programs bearing the Dolby Surround, DTS Stereo, UltraStereo or other “Surround” logos. Surround encoded programs include videocassette, DVD and LD movies, TV and cable programs, radio programs and audio CDs. Dolby Pro Logic processing may also be used to provide a pleasing surround effect with some stereophonic source material that does not carry surround encoding.	15 ms – 30 ms Initial Setting = 20 ms
DOLBY 3 STEREO	Dolby 3 Stereo uses the information contained in a surround encoded or two-channel stereo program to create center channel information. In addition, the information that is normally sent to the rear channel surround speakers is carefully mixed in with the front left and right channels for increased realism. Use this mode when you have a center channel speaker, but no surround speakers.	No Surround Channels
MOVIE SURROUND	Movie Surround processing uses matrix surround decoding, with the option to extend the delay time to 90 ms. Use this to experiment with surround times above 30 ms, or if the delay time formula suggests a longer time delay for your room.	40 ms – 90 ms Initial Setting = 40 ms
HALL SURROUND	This mode is designed for use with stereo recordings. It provides a sound-field effect that simulates the complex combination of direct and reflected sounds that create the rich reverberant atmosphere of a medium-sized circular concert hall.	40 ms – 90 ms Initial Setting = 40 ms
MATRIX SURROUND	This mode is designed for use with sports broadcasts, live concerts or other programs where the feeling of a wide surround effect is desired.	40 ms – 90 ms Initial Setting = 40 ms
STEREO	This mode turns off all surround processing and presents the pure left and right channel presentation of two channel stereo programs.	No Surround Channels

Troubleshooting

32

Troubleshooting Guide

<i>SYMPTOM</i>	<i>CAUSE</i>	<i>SOLUTION</i>
No front panel lights when power switch is pressed	<ul style="list-style-type: none">• No AC Power	<ul style="list-style-type: none">• Make certain AC power cord is plugged into a live outlet.• Check to see if outlet is switch controlled.
Display lights, but no sound or picture	<ul style="list-style-type: none">• Intermittent input connections• Mute is on• Volume control is down	<ul style="list-style-type: none">• Make certain that all input and speaker connections are secure.• Press Mute button.• Turn up volume control.
No sound from any speaker. Light around power switch is red	<ul style="list-style-type: none">• Amplifier is in protection mode due to possible short• Amplifier is in protection mode due to internal problems	<ul style="list-style-type: none">• Check speaker wire connections at receiver and speaker ends for shorts.• Contact your local Harman Kardon service depot.
No sound from surround or center speakers	<ul style="list-style-type: none">• Incorrect surround mode• Input is monaural• Incorrect configuration	<ul style="list-style-type: none">• Select a mode other than Stereo or Monaural.• There is no surround information from mono sources.• Check configuration in SET UP MENU 1.
No On-Screen Control Menus	<ul style="list-style-type: none">• TV input is S-Video	<ul style="list-style-type: none">• Change TV connection and input to Composite Video. The menus are available ONLY on Composite Video.
Unit does not respond to remote commands	<ul style="list-style-type: none">• Weak batteries in remote.• Remote is in Learn position• Remote sensor is obscured	<ul style="list-style-type: none">• Change remote batteries.• Slide Use/Learn switch to Use.• Make certain front panel sensor is visible to remote.
Intermittent buzzing in tuner	<ul style="list-style-type: none">• Local interference	<ul style="list-style-type: none">• Move unit or antenna away from computers, fluorescent lights, motors or other electrical appliances.

Memory Backup

This product is equipped with a memory backup system that preserves tuner presets and system configuration information if the unit is accidentally unplugged or subject to a power outage. This memory will last for approximately one week, after which time all information must be re-entered.

System Reset

In the rare case where the unit's operation or the displays seem abnormal, the cause may involve the erratic operation of the system's memory or microprocessor.

To correct this problem, first unplug the unit from the AC wall outlet and wait at least three minutes. After the pause, reconnect the AC power cord and check the unit's operation. If the system still malfunctions, a system reset may clear the problem.

To clear the entire system memory of the unit, press and hold the **MEMO 15** and **CLEAR 16** buttons until **CLEAR MEMO** appears in the front panel display. Release the buttons and note that the unit will turn off and then on.

Remember that once you have cleared the memory in this fashion it will be necessary to re-establish all system configuration information and tuner presets.

If the system is still operating incorrectly, there may have been an electrostatic discharge or severe AC line interference that has corrupted the memory or microprocessor.

If a reset does not solve the problem, consult an authorized Harman Kardon service depot.

Technical Specifications

33

Audio Section

Stereo Mode	
Continuous Average Power (FTC)	
70 Watts per channel 20Hz–20kHz:	
@ < 0.07% THD, both channels driven into 8 Ohms	
Five-Channel Surround Mode	
Power Per Individual Channel	
Front L&R channels:	
65 Watts per channel,	
@ 0.07% THD, 20Hz–20kHz into 8 ohms	
Center channel:	
65 Watts, 20Hz–20kHz into 8 ohms	
Surround channels:	
65 Watts per channel, 40Hz–20kHz into 8 ohms	
Input Sensitivity/Impedance	
Linear	220mV/50 Kohms
Signal-to-Noise Ratio (IHF-A)	
Linear	95dB
Surround System Adjacent Channel Separation	
Analog Decoding (Pro Logic, etc.)	40dB
Dolby Digital (AC-3)	55dB
Frequency Response	
@ 1W (+0, –3dB)	7Hz–80kHz
High Instantaneous Current Capability (HCC)	±65 amps
Transient Intermodulation Distortion (TIM)	Unmeasurable
Rise Time	16 µsec
Slew Rate	40 V/µsec

FM Tuner Section

Frequency Range	87.5–108.0 MHz
Usable Sensitivity	IHF 1.3 µV/13.5 dBf
Signal-to-Noise Ratio	Mono/Stereo 76/68dB
Distortion	Mono/Stereo 0.2/0.5%
Stereo Separation	1kHz 40dB
Selectivity	±400kHz 65dB
Image Rejection	98MHz 50dB
Tuner Output Level	1kHz, ±75kHz Dev 800mV

AM Tuner Section

Frequency Range	520–1710kHz
Signal-to-Noise Ratio	50dB
Usable Sensitivity	Loop 500 µV
Distortion	1kHz, 30% Mod 0.5%
Selectivity	±20kHz 70dB

Video Section

Television Format	NTSC
Input Level/Impedance	1Vp-p/75ohms
Output Level/Impedance	1Vp-p/75ohms
Video Frequency Response	10Hz to 8MHz (-3dB)
S/N	65dB

General

Power Requirement	AC 120V 60Hz
Power Consumption	80W idle, 325W maximum (2 channels driven)
Dimension (Max)	
Width	17.4 inches (440 mm)
Height	6.3 inches (160 mm)
Depth	18.0 inches (459 mm)
Weight	32.6 lbs. (14.8 kg)

Depth measurement includes knobs, buttons and terminal connections.

All features and specifications are subject to change without notice.

*Trademarks of Dolby Laboratories.

†DTS is a trademark of Digital Theater Systems.

**UltraStereo is a trademark of UltraStereo Corp.

harman/kardon AVR 75

DOLBY[®]
DIGITAL

AM/FM CD T-MON T*2 TV DVD V1 V2 V3

VISU
AC-3
Dolby
STEREO

